

**Dell PowerEdge VRTX System  
Upgrading PowerEdge VRTX to Support Fault  
Tolerant Shared PERC 8**



# Notes, Cautions, and Warnings

 **NOTE:** A NOTE indicates important information that helps you make better use of your computer.

 **CAUTION:** A CAUTION indicates either potential damage to hardware or loss of data and tells you how to avoid the problem.

 **WARNING:** A WARNING indicates a potential for property damage, personal injury, or death.

**Copyright © 2014 Dell Inc. All rights reserved.** This product is protected by U.S. and international copyright and intellectual property laws. Dell™ and the Dell logo are trademarks of Dell Inc. in the United States and/or other jurisdictions. All other marks and names mentioned herein may be trademarks of their respective companies.

2014 - 04

Rev. A00

# Overview of Shared PERC 8 Card Configuration

This document helps you upgrade the Dell PowerEdge VRTX system from a single controller configuration to a fault tolerant Shared PowerEdge RAID Controller (PERC) 8 configuration. The entire procedure may take you up to six hours.

The following are the two types of controller configurations:

- **Single Shared PERC 8 card configuration** — In this configuration, the PowerEdge VRTX system is installed with a single Shared PERC 8 card.
- **Fault tolerant Shared PERC 8 card configuration** — In this configuration, the PowerEdge VRTX system is installed with two Shared PERC 8 cards. Either of the two Shared PERC 8 cards can access the storage subsystem. If one Shared PERC 8 card fails, the other Shared PERC 8 card takes control in a seamless transition.

## Safety Information

 **WARNING:** Whenever you need to lift the system, get others to assist you. To avoid injury, do not attempt to lift the system by yourself.

 **WARNING:** Exercise care when removing or installing components when the system is on, to avoid the risk of electric shock. For electrostatic discharge (ESD) compliance, see [dell.com/regulatory\\_compliance](http://dell.com/regulatory_compliance).

 **CAUTION:** Many repairs may only be done by a certified service technician. You should only perform troubleshooting and simple repairs as authorized in your product documentation, or as directed by the online or telephone service and support team. Damage due to servicing that is not authorized by Dell is not covered by your warranty. Read and follow the safety instructions that came with the product.

 **CAUTION:** Do not use excessive force in either removing or reinstalling components.

 **CAUTION:** To maintain optimum thermal conditions, ensure that there are no obstructions to airflow on the front and back of the enclosure. The front and back of the enclosure must have at least 30 cm (12 inches) and 61 cm (24 inches) of unobstructed space respectively.

 **NOTE:** To ensure proper operation and cooling, all bays in the enclosure must be populated at all times with either a module or with a blank.



## Prerequisites

To upgrade the PowerEdge VRTX to support fault tolerant Shared PERC 8, you must ensure that:

- All data is backed up from the shared storage drives according to the steps required for the specific operating system.

**△ CAUTION: The upgrade procedure is complex and can put your data at risk if mistakes are made. It is imperative that critical data is backed up prior to starting the procedure.**

- The contents of the upgrade kit are checked.

The upgrade kit includes the *Upgrading PowerEdge VRTX to Support Fault Tolerant Shared PERC 8* document, the Shared PERC 8 card, the upper backplane expander board, and cables for both the backplane expander boards. The cables included in your upgrade kit may be different based on the type of hard drive backplane.

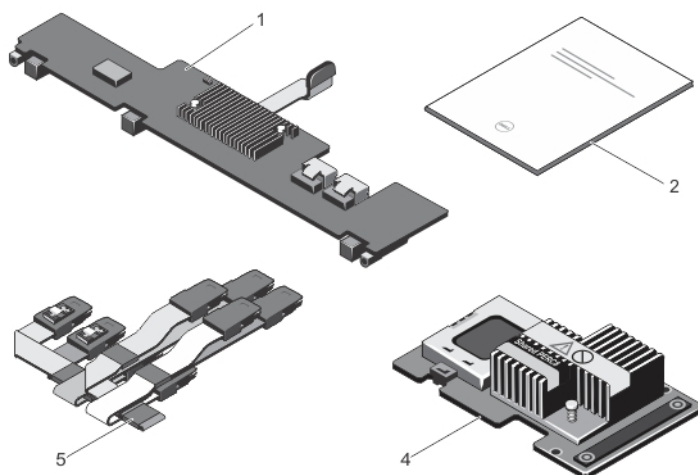

**Figure 1. Contents of the Upgrade Kit for a 3.5 inch (x12) Hard Drive Backplane**

- |                                   |                       |
|-----------------------------------|-----------------------|
| 1. upper backplane expander board | 2. upgrade guide      |
| 3. SAS cables                     | 4. Shared PERC 8 card |

- The PowerEdge VRTX nodes have the supported operating systems installed. See the latest operating system matrix for the PowerEdge VRTX system at [dell.com/ossupport](http://dell.com/ossupport).
- A management station is set up and connected to the PowerEdge VRTX CMC web interface.
- The system status and the storage status are displayed as healthy in the CMC GUI. If there are issues with either the system or the storage, resolve the issues before performing the upgrade procedure. For more information, see the CMC User Guide at [dell.com/support/manuals](http://dell.com/support/manuals).
- All required drivers and firmware are available. These include the operating system-specific Shared PERC 8 device driver, the shared hard drive firmware, the Chassis Management Controller (CMC) firmware, the Shared PERC 8 firmware, the

backplane expander board firmware, and the PowerEdge VRTX chassis infrastructure firmware. For the latest versions of drivers and firmware, see [Downloading Firmware and Drivers](#) in this document.

## Firmware Requirements

 **NOTE:** Ensure that you have uninterrupted network connectivity. The update fails if the network connectivity is interrupted during the process.

Each firmware upgrade process is described in detail in this document.

**Table 1. Firmware Required for the Upgrade Procedure**

| Firmware   | Minimum Version                                     | File Type                  | Installation Time  |
|--|---|----------------------------|--|
| Shared PERC 8 Device Driver for each server module | Windows:<br>6.802.19.0<br>ESXi 5.1:<br>06.802.71.00 | Operating system dependent | Up to 10 minutes.  |
| CMC Firmware                                       | 1.30  | .bin                       | Up to 10 minutes.<br>The process may take longer if you have a secondary CMC installed. For dual CMC, ensure two network cables are connected. |
| Shared Hard Drive Firmware                         | Depends on hard drive type                          | .exe                       | Up to 2 minutes.   |
| Chassis Infrastructure Firmware                    | 1.30  | .bin                       | Upto 25 minutes.<br>The process may take longer for dual CMCs.   |
| Shared PERC 8 Firmware                             | 23.8.10-0059  | .exe                       | Up to 10 minutes.<br>The process may take longer for updating both the Shared PERC 8 cards.  |
| Backplane Expander Board Firmware                  | 1.02  | .exe                       | Up to 2 minutes.   |

## Downloading Firmware and Drivers

1. Go to [dell.com/support/drivers](http://dell.com/support/drivers).
2. Enter the Service Tag for the PowerEdge VRTX system in the **Service Tag or Express Service Code** box and click **Submit**.
3. Under **Refine Your Results**, select the operating system.  
Ensure that you select the correct operating system.

4. Download the necessary firmware, drivers, and software.

More than one download may be available for the same component. Identify the latest software or firmware based on the release date and click **Download File**.

- a. To download the CMC firmware, expand **Chassis System Management**.
- b. To download the Shared PERC 8 firmware and driver, expand **SAS RAID**.

For VMware, the Dell latest custom VMWare .iso install image can be found on [dell.com/support](http://dell.com/support). This image contains the Shared PERC 8 device driver for ESXi. Search for the appropriate blade model and expand **Enterprise Solutions**. Alternatively, the Shared PERC 8 driver for ESXi systems can be downloaded from [vmware.com/downloads](http://vmware.com/downloads). Search for **Shared PERC**.

- c. To download hard drive firmware updates, expand **SAS Drive**.
- d. To download the PowerEdge VRTX chassis infrastructure firmware, expand **Embedded Solutions**.
- e. To download the PowerEdge VRTX backplane expander board firmware and the hard drive firmware, expand **SAS RAID**.

5. Store the files in the directory of your choice.

If there are any modular server updates available, you may also download them. You can apply the updates after you complete the upgrade procedure.





# Upgrading Your System to Fault Tolerant Shared PERC 8

 **CAUTION:** The order of the steps in this chapter is critical. Do not perform steps out of order or skip any step, or the upgrade may not be successful. Read through the entire process prior to starting the upgrade procedure.

 **NOTE:** Ensure that you have completed the conditions outlined in [Prerequisites](#) in a previous section of the document.

## Upgrade Procedure

1. Back up all data from the shared storage drives according to the steps required for the operating system.

 **CAUTION:** The upgrade procedure is complex and can put your data at risk if mistakes are made. It is imperative that critical data is backed up prior to starting the procedure.

2. Document your virtual drive configuration and mapping information after obtaining the configuration information by following the steps:
  - From the CLI terminal, run the command `racadm raid get vdisks -o` to get the virtual disk configuration and server node mapping.  
Take a screen shot of the results page or copy the results to a file. Save either file to a safe and secure location of your choice.
  - Click **Chassis Overview** → **Storage** → **Virtual Disks** → **Assign** to view the virtual disk mapping by the CMC GUI.  
Take a screen shot of the results page or copy the results to a file. Save either file to a safe and secure location of your choice.
  - Click **Chassis Overview** → **Storage** → **Virtual Disks** to get the virtual disk configuration information by the CMC GUI.  
Take a screen shot of the results page or copy the results to a file. Save either file to a safe and secure location of your choice.
3. Update the operating system-specific Shared PERC 8 device driver on all the server modules.  
For Windows operating system, see the Shared PERC 8 User's Guide at [dell.com/storagecontrollermanuals](http://dell.com/storagecontrollermanuals) . For VMware, the driver is a part of the Dell-customized ESXi image. For more information, see *Installing async drivers* at [kb.vmware.com](http://kb.vmware.com) .
4. Turn off all the server modules.
5. Update the hard drive firmware for all the shared hard drives.  
For more information, see [Updating the Shared Hard Drive Firmware](#).
6. Turn off the PowerEdge VRTX system.

7. Remove the server modules and the shared storage hard drives from the PowerEdge VRTX system.

 **WARNING: To prevent damage, do not stack components together after removal. For electrostatic discharge (ESD) compliance, see [dell.com/regulatory\\_compliance](http://dell.com/regulatory_compliance).**

Label all server modules and hard drives before removal so that they can be replaced in the same slots.

8. Update the CMC firmware.

For more information, see [Updating the CMC Firmware](#) in this document.

During the CMC firmware update process, the CMC resets to activate the new firmware. This results in the CMC interface being unavailable for a few minutes.

9. Turn on the VRTX system and log in to the CMC GUI.

10. Click **Chassis Overview** → **Power** → **Control** and view the **Power State** to ensure that it is **ON**.

The PowerEdge VRTX storage subsystem may take up to 25 minutes to become online.

11. Update the PowerEdge VRTX chassis infrastructure firmware.

For more information, see [Updating the PowerEdge VRTX Chassis Infrastructure Firmware](#) in this document.

At the end of the PowerEdge VRTX chassis infrastructure firmware update process, the system automatically performs a power reset to activate the new firmware. It may take up to 25 minutes for the storage subsystem to become online.

12. Update the Shared PERC 8 firmware for the existing Shared PERC 8 card in the system.

For more information, see [Updating the Shared PERC 8 Firmware](#) in this document.

 **NOTE:** The additional Shared PERC 8 card has not yet been installed.

13. Update the PowerEdge VRTX backplane expander board firmware.

For more information, see [Updating the Backplane Expander Board Firmware](#).

14. Turn off the PowerEdge VRTX system.

15. Prepare the PowerEdge VRTX system for installing the hardware from the upgrade kit.

For more information, see [Preparing the PowerEdge VRTX System to Support Fault Tolerant Shared PERC 8](#) in this document.

16. Install the second Shared PERC 8 and the upper backplane expander board in the PowerEdge VRTX system.

For more information, see [Installing the Contents of the Upgrade Kit](#) in this document.

17. Turn on the PowerEdge VRTX system.

18. Go to the **Chassis Overview** → **Storage** → **Controllers** page and ensure that both the Shared PERC 8 cards have the updated firmware and are in an active and fault tolerant mode.

 **NOTE:** If you do not have a healthy fault tolerant status, click the label link to troubleshoot the issue. Also, ensure that the second Shared PERC 8 card is seated properly and is displayed in the CMC GUI.

 **NOTE:** If the Shared PERC 8 cards or the backplane expander boards have different versions of their firmware, update the firmware. See the related sections in the document.

19. After the system completes powering on, power cycle the PowerEdge VRTX system once again.

Confirm the power status in the CMC **Chassis Overview Page**.

20. Reconfirm that the system status and fault tolerant status is still healthy.

This is necessary to ensure that all new firmware has been initialized and is compatible before you reinsert the shared hard drives and modular servers.

21. Turn off the PowerEdge VRTX system.

22. Insert the shared storage hard drives that you had removed earlier. Insert the shared hard drives in the original slots.
23. Turn on the PowerEdge VRTX system.
24. Confirm the **Virtual Disk Layout** and the **Virtual Disk Assignments** in the CMC GUI. If the virtual disks are not imported, not present, or the virtual disk assignments are not present or wrong, contact Dell Technical Support.
25. Turn off the PowerEdge VRTX system.
26. Insert the server modules that you had removed earlier. Insert the server modules in the original slots.
27. Turn on the PowerEdge VRTX system.
28. Turn on the server modules.
29. Configure multipath for the Windows operating system.  
For information on multipath, see [Information about Configuring Multipath](#).

## Updating the Shared Hard Drive Firmware

Click **Chassis Overview** → **Storage** → **Update** and see if the shared hard drive firmware needs to be updated. For the latest drivers and firmware versions, see [dell.com/support/drivers](http://dell.com/support/drivers).

1. Log in to the CMC GUI by using the management station.  
The **Chassis Overview** page is displayed.
2. Navigate to **Storage** in the left pane and click the **Update** tab in the right pane.  
The **Storage Component Update** page is displayed.
3. In **Select the Update Package**, click **Browse** and select the shared hard drive firmware you downloaded by following the steps in [Downloading Firmware and Drivers](#).
4. Select the hard drive component or components and click **Update**.
5. If the upgrade is successful, the status of the page changes to the updated firmware.

Click **Chassis Overview** → **Storage** and check the firmware version to see if the process was successful.

## Updating the CMC Firmware

 **NOTE:** Screen captures of the application are only for reference. Updates may have been made to the application after publication of this document.

Click **Chassis Overview** → **Update** and see if the CMC firmware needs to be updated.

1. Log in to the CMC GUI by using the management station.
2. In **Chassis Overview**, click the **Update** tab in the right pane.

The **Firmware Update** page is displayed.

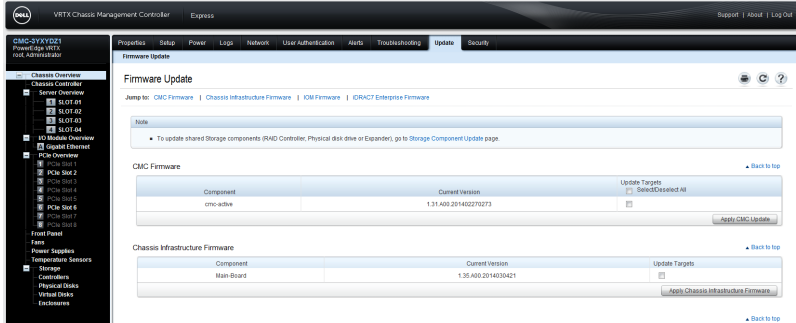

Figure 2. Updating the CMC Firmware

3. Select the check box under **CMC Firmware** and click **Apply CMC Update**.



**NOTE:** If you have two CMC applications, select both.

4. Click **Browse** and select the CMC firmware update you downloaded by following the steps in [Downloading Firmware and Drivers](#).
5. Click **Begin Firmware Update**.

During this process, the CMC software goes offline for some time.

Check the CMC firmware version again to see if the update was successful.

## Updating the PowerEdge VRTX Chassis Infrastructure Firmware

Click **Chassis Overview** → **Update** and see if the PowerEdge VRTX chassis infrastructure firmware needs updating.

1. Log in to the CMC GUI by using the management station.
2. Confirm that the PowerEdge VRTX chassis is turned **on** in **Chassis Overview** → **Power**.
3. Confirm that the server modules are turned **off** in **Server Overview** → **Power**.
4. Navigate to **Chassis Overview**, click the **Update** tab.  
The **Firmware Update** page is displayed.
5. Under **Chassis Infrastructure Firmware**, click **Apply**.
6. Click **Browse** and select the chassis infrastructure firmware update you downloaded by following the steps in [Downloading Firmware and Drivers](#).
7. Click **Begin Firmware Update**.

After the firmware update is complete, the PowerEdge VRTX system power cycles to initialize the updated firmware. The process takes up to 25 minutes.

8. Click **Chassis Overview** → **Update Page** to confirm that the firmware is updated.

## Updating the Shared PERC 8 Firmware

Click **Chassis Overview** → **Storage** → **Update** and see if the Shared PERC 8 firmware needs updating.

1. Log in to the CMC GUI by using the management station.
2. Ensure that the PowerEdge VRTX system is turned on in **Chassis Overview** → **Power**.
3. Ensure the server modules are turned **off** in **Server Overview** → **Power**.
4. Navigate to **Storage** in the left pane and click the **Update** tab.

The **Storage Component Update** page is displayed.

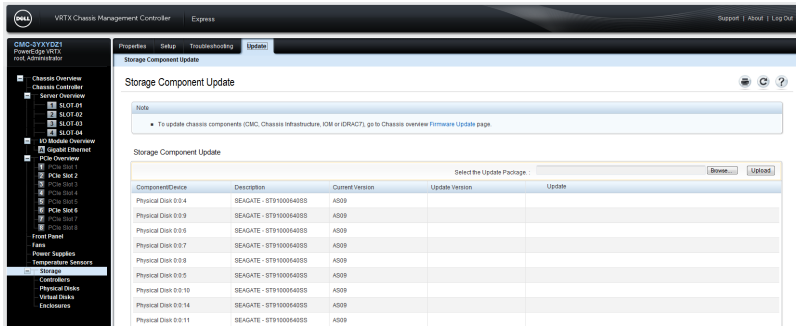

Figure 3. Updating the Shared PERC 8 Firmware

5. In **Select the Update Package**, click **Browse** and select the Shared PERC 8 firmware you downloaded by following the steps in [Downloading Firmware and Drivers](#).

The CMC software analyzes the firmware file and if you had downloaded the correct package for the Shared PERC 8 card, the **Storage Component Update** page displays the PERC controller.

6. Select the **RAID Controller** and click **Update**.  
A message is displayed stating that the PowerEdge VRTX system must be turned off.
7. Click **OK** to proceed.  
After the Shared PERC 8 firmware update is complete, the controller resets itself so no power cycling is required. If there are two Shared PERC 8 cards and they have different firmware revisions installed, select the PERC card that needs the upgrade. If both the cards have the same firmware revision installed, both cards are displayed as a single component in the CMC GUI.
8. If the upgrade is successful, the status of the page changes to show the updated firmware.

## Updating the Backplane Expander Board Firmware

Click **Chassis Overview** → **Storage** → **Update** and see if the backplane expander board firmware needs updating.

1. Log in to the CMC GUI by using the management station.  
The **Chassis Overview** page is displayed.
2. In the left pane, click **Storage** and then click the **Update** tab in the right pane.  
The **Storage Component Update** page is displayed.

3. In **Select the Update Package**, click **Browse** and navigate to the firmware package you downloaded by following the steps in [Downloading Firmware and Drivers](#).

The CMC software analyzes the firmware file and if you have downloaded the correct package, the **Storage Component Update** page displays the backplane expander board component.

4. Select the expander component and click **Update**.

 **NOTE:** If there are two backplane expander boards and they have different firmware revisions installed, click **Select All**.

5. If the upgrade is successful, the status of the page changes to show the updated firmware version.

You are now ready to install the components of the upgrade kit.

## Preparing the PowerEdge VRTX System to Support Fault Tolerant Shared PERC 8

 **CAUTION:** Do not stack components together after removal. For electrostatic discharge (ESD) compliance, see [dell.com/regulatory\\_compliance](http://dell.com/regulatory_compliance).

 **CAUTION:** Do not apply force on the SAS cable connector. To remove the SAS cable, press on the middle tab and push forward to disengage the cable from the SAS cable connectors. Gently pull back the cable to remove it from the connector.

 **CAUTION:** Handle backplane expander boards with both hands and with care.

 **NOTE:** You may need to see the *Dell PowerEdge VRTX Enclosure Owner's Manual* at [dell.com/support/manuals](http://dell.com/support/manuals) for more information on removing and reinstalling components.

 **NOTE:** Steps 1 to 3 may already be complete if you have followed instructions in the previous sections of the document.

1. Turn off the server modules using the operating system commands or the CMC.
2. Turn off the PowerEdge VRTX system and attached peripherals, and disconnect the system from the electrical outlet.
3. Remove the following components in order:
  - a. Front Bezel
  - b. Server Modules
  - c. Hard Drives

Label all server modules and hard drives before removal so that they can be replaced in the same slots.

4. If applicable, rotate the system feet inward and lay the system on its side on a flat stable surface, with the cover release latch side on top.
5. Open the system.

6. Remove the cooling shroud.

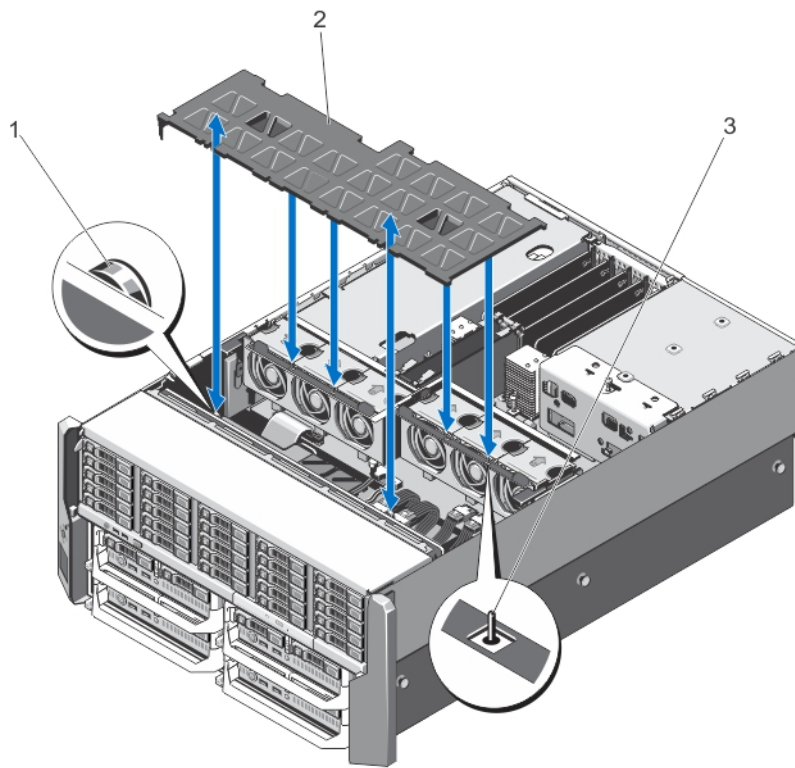

**Figure 4. Removing and Installing the Cooling Shroud**

- 1. release pins on the hard-drive backplane
- 2. cooling shroud
- 3. pin on the cooling fan assembly

7. Remove the cooling-fan assembly.

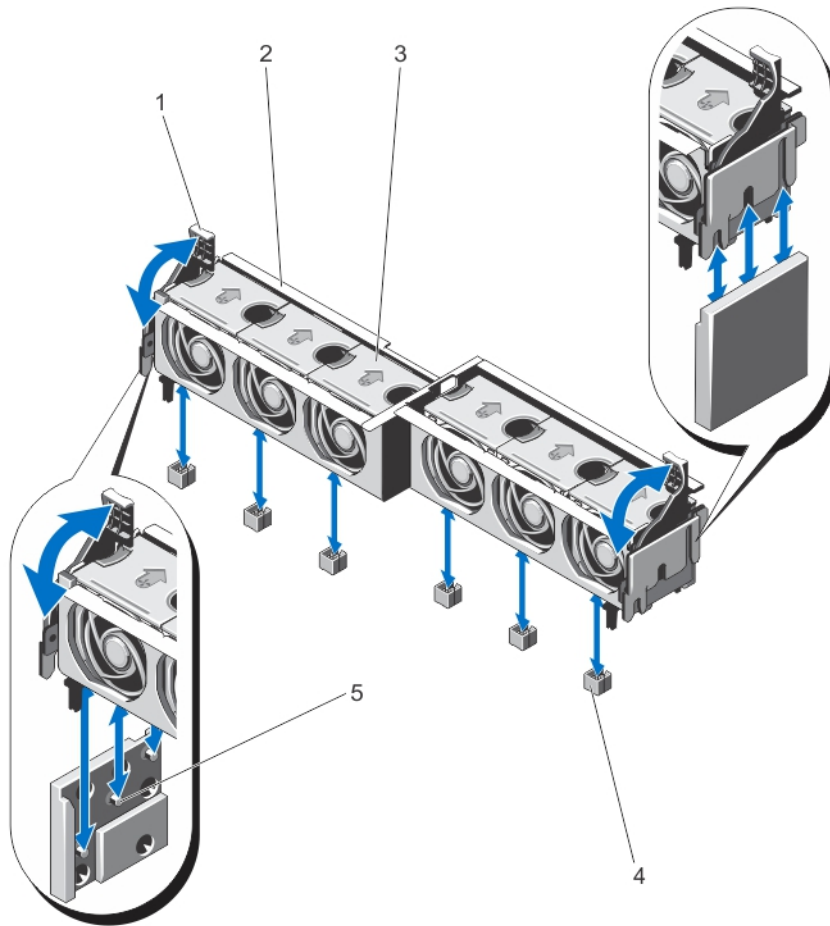
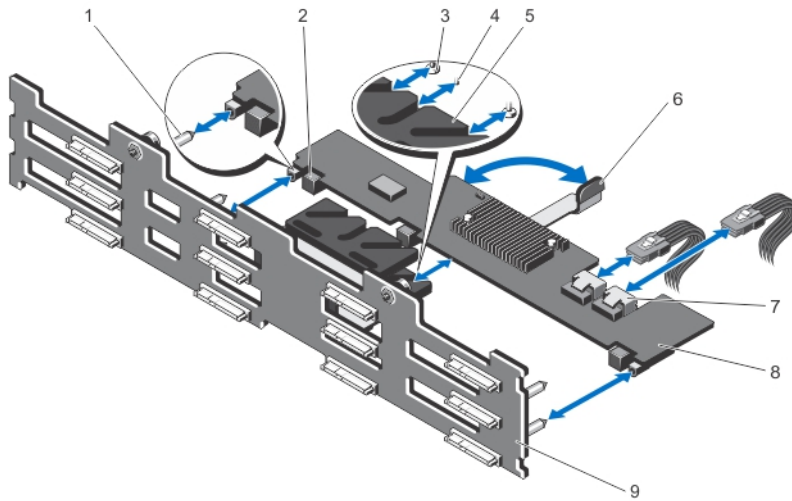

**Figure 5. Removing and Installing the Cooling-Fan Assembly**

- |                         |                               |
|-------------------------|-------------------------------|
| 1. release levers (2)   | 2. cooling-fan assembly       |
| 3. cooling fans (6)     | 4. cooling-fan connectors (6) |
| 5. support brackets (2) |                               |
8. For the 2.5" hard-drive chassis, remove the SAS cables from the system board and the backplane expander board.
  - NOTE:** The next steps are applicable for the 3.5" hard drive chassis only. If you have a 2.5" hard drive chassis, go to the next section [Installing the Contents of the Upgrade Kit](#).
  9. Remove the SAS cables from the backplane expander board .
  10. Rotate the release lever outward to disengage the backplane expander board connectors from the connectors on the hard-drive backplane.



11. Remove the backplane expander board from the connectors on the hard-drive backplane.

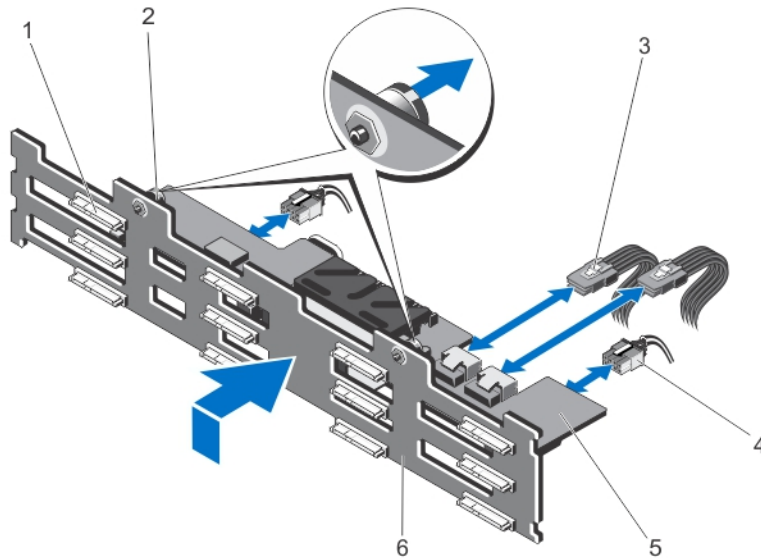

**Figure 6. Removing and Installing the 3.5 inch Backplane Expander Board**

- |  |   |
|--|---|
| 1. guide pins on the hard-drive backplane (2)                          | 2. backplane expander board connectors (3)                  |
| 3. securing screws on the release lever (under the expander board) (2) | 4. standoff on the release lever (under the expander board) |
| 5. expander board bracket  | 6. release lever  |
| 7. SAS cable connectors (2)  | 8. backplane expander board                                 |
| 9. hard-drive backplane  |   |

12. Disconnect the backplane power cables and the optical drive SATA and power cables from the system board.

13. Pull the backplane release pins in the direction of the system board and lift the backplane from the chassis.  
Keep the lower corner of the backplane near the SAS cable clear of the EMI gasket as you lift the backplane up.



**Figure 7. Removing and Installing the 3.5 inch (x12) Hard-Drive Backplane**

- |   |                         |
|---|-------------------------|
| 1. hard-drive connectors (12)                 | 2. release pins (2)     |
| 3. SAS cables on backplane expander board (2) | 4. power cables (2)     |
| 5. backplane expander board                   | 6. hard-drive backplane |

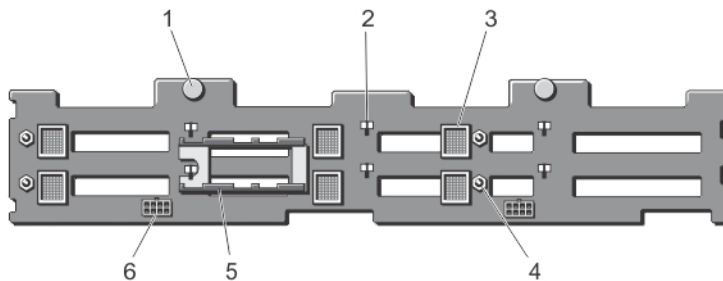

**Figure 8. Back View of the 3.5 inch (x12) Hard-drive Backplane**

- |  |   |
|--|---|
| 1. release pins (2)                        | 2. slots for chassis hooks (10)                 |
| 3. backplane expander board connectors (6) | 4. guide pins for backplane expander boards (4) |
| 5. backplane expander board brackets (2)   | 6. power cable connectors (2)                   |

14. Remove the SAS cables from the system board.

## Installing the Upgrade Kit

**⚠ CAUTION: Handle the backplane expander board with care.**

Before following the steps in this section, see [Preparing the PowerEdge VRTX System to Support Fault Tolerant Shared PERC 8](#).

For more information on removing and reinstalling system components, see the *Dell PowerEdge VRTX Enclosure Owner's Manual* at [dell.com/support/manuals](http://dell.com/support/manuals).

1. Remove the protective caps from the SAS cable connectors.
2. Install one end of each of the SAS cables in the system board.  
The ends that are connected to the system board are labeled as **MB SAS 1A**, **MB SAS 1B**, **MB SAS 2A**, and **MB SAS 2B**.

Remove the grey protective caps on the SAS cable connectors , **MB SAS 2A**, and **MB SAS 2B**, on the system board.

Ensure that the other ends of the SAS cables are routed toward the back of the chassis.

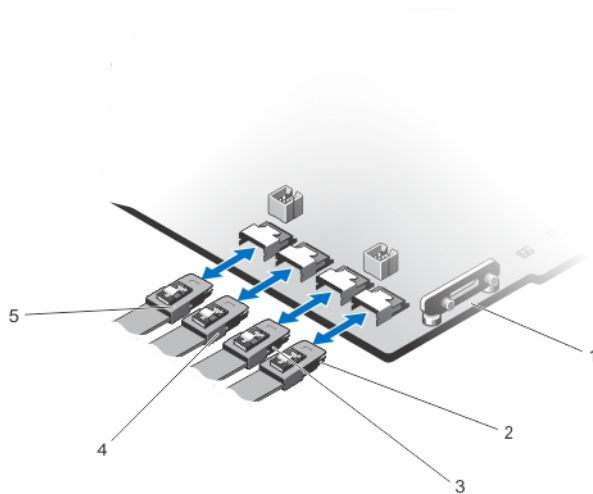

**Figure 9. Installing the SAS Cables in the System Board**

- |                 |             |
|-----------------|-------------|
| 1. system board | 2. MB SAS1A |
| 3. MB SAS1B     | 4. MB SAS2A |
| 5. MB SAS2B     |             |

 **NOTE:** Steps 3 to 7 apply to PowerEdge VRTX systems with 3.5-inch hard drives. If you have 2.5-inch hard drives, see step 8.

3. Position the hard-drive backplane onto the chassis hooks with care and slide down the backplane until both the release pins align with the slots on the chassis and click into place.
4. Connect the hard-drive backplane power cable and the optical drive SATA and power cables to the system board.

5. Install the lower backplane expander board.

Use both hands to insert the backplane expander board, and ensure that the backplane expander board connectors (3) are properly inserted and engaged even after the release lever is secured.

- a. Ensure that the backplane expander board release lever is fully opened.
- b. Position the backplane expander board so that the two guide rails under the expander board align with the two guide posts on the hard-drive backplane.

The securing screws and standoff on the release lever (under the expander board) slide into the slots on the expander board bracket on the hard-drive backplane.

- c. Rotate the release lever inward until it is level with the expander board and the expander board connectors fully engage with the hard-drive backplane connectors. It may be necessary to firmly push on the expander to fully engage the connectors.

6. Connect the SAS cables to the lower backplane expander board.

Make sure that both SAS connectors are latched.



**NOTE:** The ends of the SAS cables that are plugged into the lower backplane expander board have the labels **LOW EXP SAS A** and **LOW EXP SAS B** marked on the cables.

7. Install the upper backplane expander board.



**CAUTION:** Handle the backplane expander board with care so as not to damage any component.

- a. Ensure that the backplane expander board release lever is fully opened.
- b. Position the backplane expander board so that the two guide rails under the expander board align with the two guide posts on the hard-drive backplane.

The securing screws and standoff on the release lever (under the expander board) slide into the slots on the expander board bracket on the hard-drive backplane.

- c. Rotate the release lever inward until it is level with the expander board and the expander board connectors fully engage with the hard-drive backplane connectors. It may be necessary to firmly push on the expander to fully engage the connectors.

8. Connect the SAS cables to the upper backplane expander board.  
Make sure that both SAS connectors are latched.

 **NOTE:** The ends of the SAS cables that are plugged into the upper backplane expander board have the labels **UP EXP SAS A** and **UP EXP SAS B** marked on the cables.

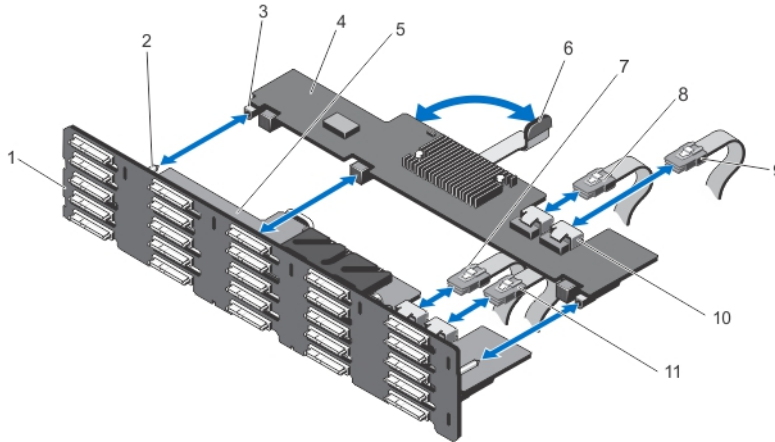

**Figure 10. Installing the Upper Backplane Expander Board**

- |  |   |
|--|---|
| 1. backplane                               | 2. guide pins on the hard-drive backplane (2) |
| 3. backplane expander board connectors (3) | 4. backplane expander board                   |
| 5. lower backplane expander board          | 6. release Lever                              |
| 7. LOW EXP SAS A                           | 8. UP EXP SAS A                               |
| 9. UP EXP SAS B                            | 10. SAS slot on backplane expander board      |
| 11. LOW EXP SAS B                          |   |

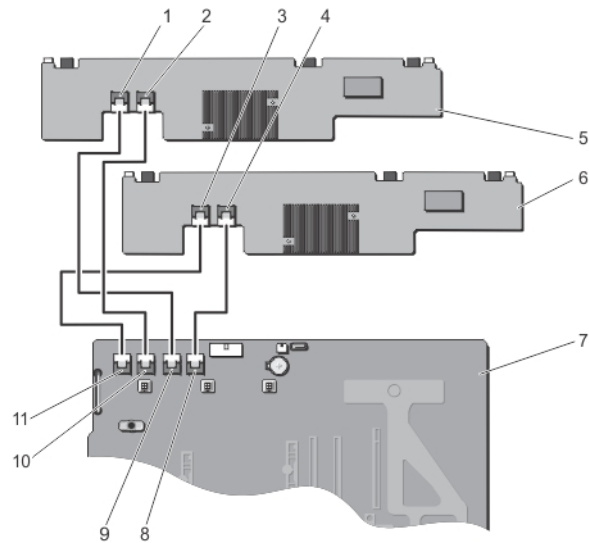

**Figure 11. Cabling Diagram**

- |                                   |                                   |
|-----------------------------------|-----------------------------------|
| 1. UP EXP SASA                    | 2. UP EXP SASB                    |
| 3. LOW EXP SASA                   | 4. LOW EXP SASB                   |
| 5. upper backplane expander board | 6. lower backplane expander board |
| 7. system board                   | 8. MB SAS2B                       |
| 9. MB SAS2A                       | 10. MB SAS1B                      |
| 11. MB SAS1A                      |                                   |

9. Install the second Shared PERC 8 card.

Insert the left edge of the Shared PERC 8 card into the card holder first. Only after the left end is inserted, press down on the touchpoints on the other end of the card until the release levers snap over the edge of the card. Hold the Shared PERC 8 card only by the card edges. Do not damage the heatsink.

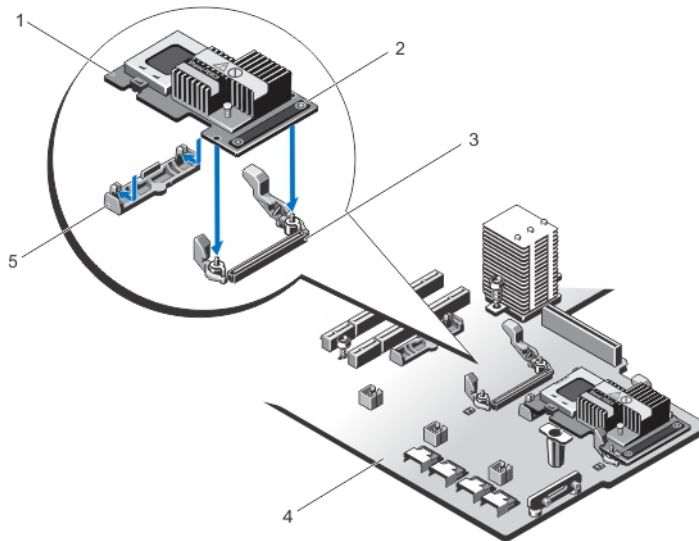

Figure 12. Installing the Second Shared PERC 8 Card

- |  |  |
|--|--|
| 1. Shared PERC 8 card left edge— This is inserted first  | 2. Shared PERC 8 card right edge with 2 touch points |
| 3. storage-controller card connector on the system board | 4. system board                                      |
| 5. storage-controller card holder                        |  |

10. Install the cooling fan assembly.

11. Install the cooling fan shroud.

When installing the cooling fan shroud, there must be no resistance. If you have difficulty in installing the cooling fan shroud, reseal the cooling fan assembly and check that all the cooling fans are firmly seated.

12. Close the system.

13. If applicable, place the system upright on a flat, stable surface and rotate the system feet outward.

14. Reconnect the system to the electrical outlet.

## Information about Configuring Multipath

Multipath is an operating system level framework designed to mitigate the effects of a host bus adapter (HBA) failure by providing an alternate data path between storage devices and the operating system.

Multipath can be configured on Windows and VMware:

- For VMware — NMP (Native Multipath) is the VMware multipath framework. NMP is configured automatically when multiple paths to storage are discovered. In standard VRTX installations, the default NMP settings may be used. NMP paths can be confirmed in vSphere by selecting the ESX Server and going to **Configuration** → **Storage** and selecting a **Datastore**. The path count and health are listed in the bottom panel.

- For Windows — MPIO (Multipath IO) is the Microsoft Windows multipath service. To configure MPIO, first create VDs and assign the VDs to the server modules that support MPIO. MPIO requires a storage controller and a storage endpoint (VD) to determine the storage I/O path. In standard VRTX configurations, the default MPIO settings can be used. See *Installing and Configuring MPIO* at **[technet.microsoft.com](http://technet.microsoft.com)**.



# Troubleshooting the Upgrade Procedure

When upgrading the Entry Shared PowerEdge VRTX storage subsystem to Fault Tolerant configuration, it is critical that you follow the steps in order. Observe the following precautions:

- Back up all critical data to a storage independent of the PowerEdge VRTX storage subsystem.
- Record the storage configuration and mapping information to a storage independent of the PowerEdge VRTX storage subsystem.
- Observe safety guidelines when handling electronic equipment.
- Do not exert too much pressure when removing and reinstalling hardware components.

Failure to follow the steps in this document may result in the following issues:

- Shared storage virtual disk to server node mapping may be lost or changed.
- Fault tolerance may be reported as degraded in CMC.
- The PowerEdge VRTX system may fail to become operational.

## Basic Troubleshooting Steps

For any issue, perform the following checks:

- All hardware components are properly seated. This includes the hard-drive backplane, the backplane expander boards, the Shared PERC 8 cards, and any other hardware that you may have reinstalled during the upgrade procedure.
- All the cables are connected and routed in the chassis as instructed in this document.
- All components have been updated to the latest driver or firmware version.

## Troubleshooting the Storage Subsystem

If the basic troubleshooting steps did not resolve the issue, perform the following steps:

1. Turn off all the server modules and the PowerEdge VRTX system.
2. Remove the shared drives from the PowerEdge VRTX system.
3. Turn on the PowerEdge VRTX system and confirm if fault tolerance is enabled.
4. Turn off the PowerEdge VRTX system.
5. Reinsert the shared drives in the system.
6. Turn on the PowerEdge VRTX system.
7. Log in to the CMC GUI and confirm the shared storage virtual disk to blade mapping is correct:
  - a. Click **Chassis Overview** → **Storage** → **Virtual Disks** → **Assign**.
  - b. If the mapping no longer exists or is incorrect, reconfigure the mapping in the **Assign** page in CMC. Power cycle the system and confirm the mapping changes.

If Virtual Disk mapping is still missing or incorrect; perform the following steps:

8. Turn off all the server modules and the PowerEdge VRTX system.

9. Remove all hard drives from the PowerEdge VRTX system.
10. Power on the PowerEdge VRTX system and check if full fault tolerance is enabled.

 **WARNING: The following step must be performed after all the shared hard drives are removed from the system. Performing the next step with the shared drives in the PowerEdge VRTX system will result in the removal of all configured virtual disks and all data contained within.**

11. Reset your storage configuration from the CMC:
  - a. Click **Chassis Overview** → **Storage** → **Controllers**.
  - b. Select the **Troubleshooting** tab.
  - c. Under **Actions** column, select **Reset Configuration** in the drop down box.Perform this step for each of the controllers.

The VD configuration is restored when you re-insert the shared hard drives.

12. Turn off the PowerEdge VRTX system.
13. Reinsert the shared hard drives and turn on the PowerEdge VRTX system.  
The virtual drives are automatically re-imported.
14. Click **Chassis Overview** → **Storage** → **Virtual Disks** and confirm all virtual disks have been successfully imported.  
Virtual Disks are listed in the **Properties** tab.
15. From CMC, re-apply the VD to blade mapping:
  - a. Navigate to **Chassis Overview** → **Storage** → **Virtual Disks**.
  - b. Select the **Assign** tab.
  - c. Apply the mapping from this page.

If the preceding steps fail to resolve your issue, contact Dell technical support.

# Getting Help

## Contacting Dell

 **NOTE:** Dell provides several online and telephone-based support and service options. If you do not have an active Internet connection, you can find contact information on your purchase invoice, packing slip, bill, or Dell product catalog. Availability varies by country and product, and some services may not be available in your area.

To contact Dell for sales, technical support, or customer-service issues:

1. Go to **dell.com/support**.
2. Select your country from the drop-down menu on the top left corner of the page.
3. For customized support:
  - a. Enter your system service tag in the **Enter your Service Tag** field.
  - b. Click **Submit**.  
The support page that lists the various support categories is displayed.
4. For general support:
  - a. Select your product category.
  - b. Select your product segment.
  - c. Select your product.  
The support page that lists the various support categories is displayed.

## Locating Your System Service Tag

Your system is identified by a unique Express Service Code and Service Tag number. The Express Service Code and Service Tag are found on the front of the system by pulling out the information tag. Alternatively, the information may be on a sticker on the chassis of the system. This information is used by Dell to route support calls to the appropriate personnel.

## Documentation Feedback

If you have feedback for this document, write to **documentation\_feedback@dell.com**. Alternatively, you can click on the **Feedback** link in any of the Dell documentation pages, fill out the form, and click **Submit** to send your feedback.

## Related Documentation

 **WARNING:** See the safety and regulatory information that shipped with your system. Warranty information may be included within this document or as a separate document.

- The *Dell PowerEdge VRTX Getting Started Guide* shipped with your system provides an overview of system features, setting up your system, and technical specifications.
- The setup placemat shipped with your system provides information on the initial system setup and configuration.
- The server module Owner's Manual provides information about the server module features and describes how to troubleshoot the server module and install or replace the server module components. This document is available online at [dell.com/poweredgemanuals](http://dell.com/poweredgemanuals).
- The *Updating Servers of M1000e Chassis and Using in VRTX Chassis* provides information on updating M1000e server modules to be used in the VRTX chassis, using the Chassis Management Controller. This document is available online at [dell.com/esmmanuals](http://dell.com/esmmanuals).
- The rack documentation included with your rack solution describes how to install your system into a rack, if required.
- The I/O module documentation at [dell.com/poweredgemanuals](http://dell.com/poweredgemanuals) describes the features of the I/O module installed in the VRTX enclosure.
- The *Dell Shared PowerEdge RAID Controller (PERC) 8 User's Guide* provides information about deploying the Shared PERC 8 card and managing the storage subsystem. This document is available online at [dell.com/poweredgemanuals](http://dell.com/poweredgemanuals).
- The *Upgrading PowerEdge VRTX to Support Fault Tolerant Shared PERC 8 Information Update* provides information on upgrading to fault-tolerant Shared PERC 8. This document is available online at [dell.com/poweredgemanuals](http://dell.com/poweredgemanuals).
- The *Dell Chassis Management Controller for Dell PowerEdge VRTX User's Guide* provides information on installing, configuring and using the Chassis Management Controller (CMC). This document is available online at [dell.com/esmmanuals](http://dell.com/esmmanuals).
- The *Dell PowerEdge VRTX Chassis Management Controller Firmware Event Message Reference Guide* provides information on the error and event messages generated by the firmware or other agents that monitor system components. This document is available at [dell.com/esmmanuals](http://dell.com/esmmanuals).
- The *CMC Online Help* provides information and instructions for the current page on the CMC web interface. To access the *Online Help*, click **Help** on the CMC web interface.
- The *Integrated Dell Remote Access Controller (iDRAC) User's Guide* provides information about installation, configuration and maintenance of the iDRAC on managed systems. This document is available online at [dell.com/esmmanuals](http://dell.com/esmmanuals).
- Dell systems management application documentation provides information about installing and using the systems management software.
- For the full name of an abbreviation or acronym used in this document, see the Glossary at [dell.com/support/manuals](http://dell.com/support/manuals).
- Any media that ships with your system that provides documentation and tools for configuring and managing your system, including those pertaining to the operating system, system management software, system updates, and system components that you purchased with your system.

 **NOTE:** Ensure that all the component software are upgraded to the latest versions. For information on the latest supported firmware and driver versions, see the **Drivers & Downloads** link on [dell.com/support/drivers](http://dell.com/support/drivers), for your system.

 **NOTE:** Always check for updates on [dell.com/support/manuals](http://dell.com/support/manuals) and read the updates first because they often supersede information in other documents.